

CONFIDENTIAL NOTICE: This drawing and the designs, specifications and engineering information disclosed herein are the property of Eberhard Manufacturing Company and are not to be disseminated or reproduced without express written consent. The drawing is loaned in confidence and then only for consideration of the matter disclosed herein. In accepting loan of this drawing, recipient agrees to keep it and the matter disclosed herein in confidence and not to use nor permit their use in any way detrimental to Eberhard Manufacturing Company, Division of the Eastern Company, 21944 Drake Road, Cleveland, Ohio 44149-9712. © 2013 EBERHARD MFG. CO.

REVISION HISTORY			
REV	DESCRIPTION	EN	DATE
	CONVERTED TO 3D	5620	9-6-13

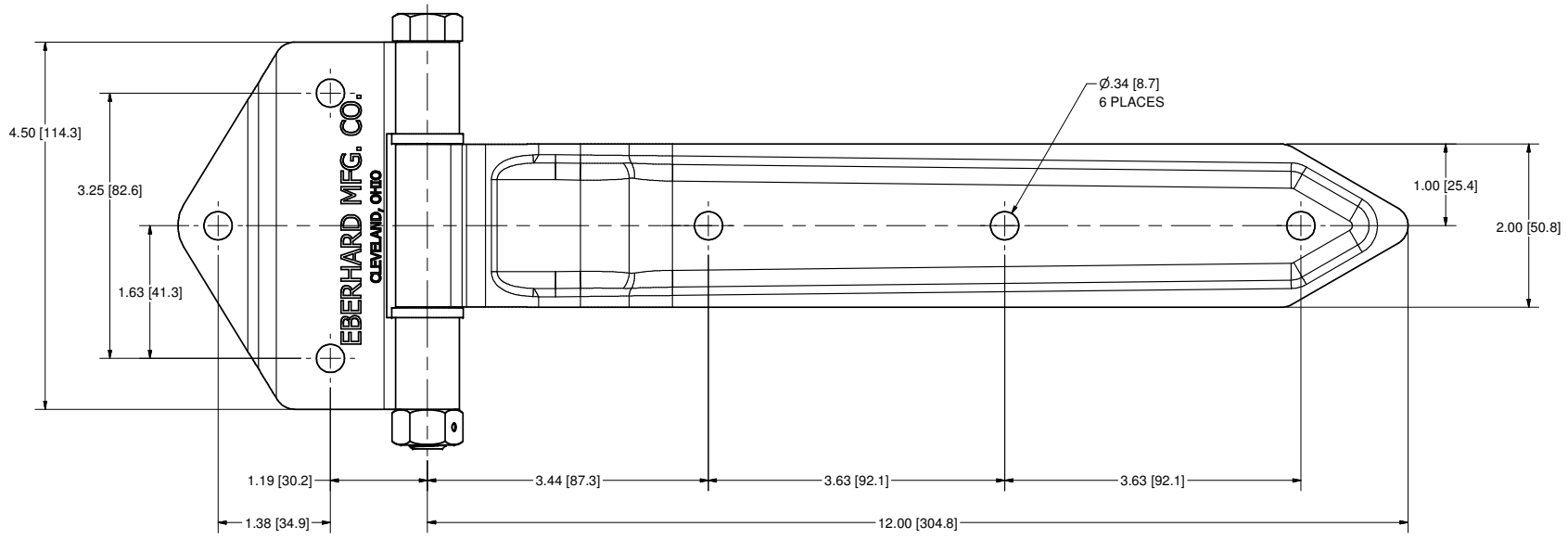
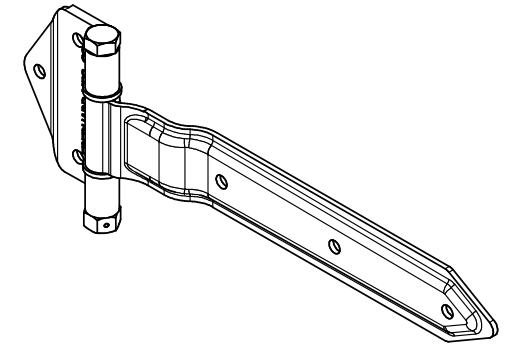

NOTE: FINISHES:
 A. ELECTROZINC, FC (25)
 B. HOT DIP GALVANIZED, FC (13)

SUPERSEDES DRAWING 1-5890-X SHEET 1 OF 2 DATED 6-9-05.

THIS DOCUMENT IS IN ACCORDANCE WITH ASME Y14.19-2009			
LINEAR MEASURE		INCH	DATE
UNLESS OTHERWISE SPECIFIED			9/6/2013
TOLERANCES ARE AS FOLLOWS:			DRW BY
	IN	MM	FLP
ANGLES:	° F	° C	FILE
2 PLACE DEC:	± .03	± .76	CHK BY
3 PLACE DEC:	± .015	± .38	
ALL HOLES:	± .005	± .13	

[M.M.]
 CUSTOMER PRINT
 SHEET 1 OF 2

EBERHARD MANUFACTURING CO.
 DIVISION OF
 THE EASTERN COMPANY
 CLEVELAND, OHIO 44149-9712

**OVER THE SEAL TYPE HINGE
 ASSEMBLY w/REMOVABLE PIN**

MATERIAL: _____ PART NUMBER: **1-5869-X**

C:\Working_Folder\Archive\Pro\558XX\1-5890-X GH1.idw