

CONFIDENTIAL NOTICE: This drawing and the designs, specifications, and engineering information hereon are the property of Eberhard Manufacturing Company and are not to be disseminated or reproduced without express written consent. This drawing is loaned in confidence and then only for the consideration of the matter disclosed hereon. In accepting loan of this drawing, recipient agrees to keep it and the matter disclosed hereon in confidence and not to use or permit their use in any way detrimental to Eberhard Manufacturing Company, Division of The Eastern Company, 21944 Drake Road, Cleveland, Ohio, 44149-9712 © 2023 EBERHARD MFG. CO.

REVISION HISTORY					
REV	DESCRIPTION	EN	DATE	REV. BY	APVD BY
0	REVISED AND REDRAWN, CHGD FROM LC BORDER, PER CPP4312.	6128	12/8/2023	KAB	MR
1	ADDED EMC SUPPORT CARD AND SILICA GEL PACK TO BAG	6148	05/03/2024	MAM	MR

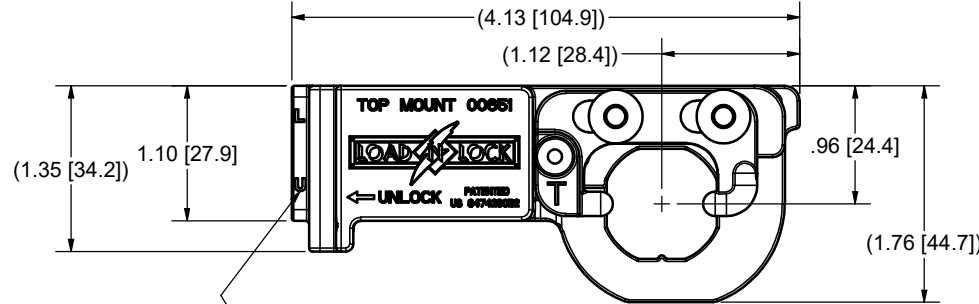

POLARITY NEEDS TO BE WHEN (+) DVC IS APPLIED TO 9U0 TERMINAL THE SOLENOID IS RETRACTED AS SHOWN.

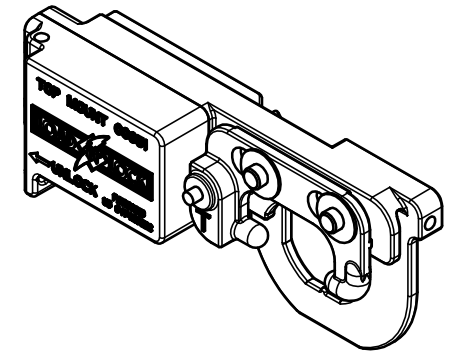

NOTE: INSTALL 00667 WASHER THEN WELD, MAINTAIN MIN. 0.010" CLEARANCE BETWEEN PARTS 00638 AND 00645 FOR SMOOTH MOVEMENT

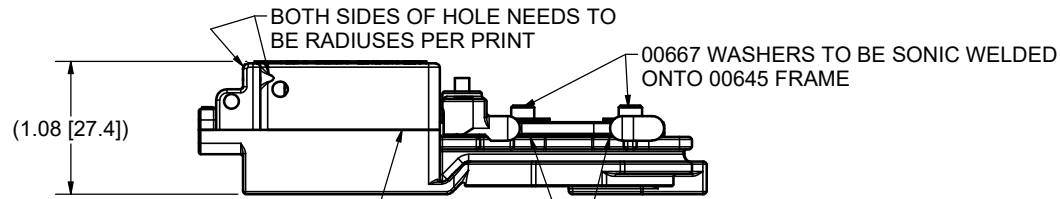

SONIC WELD PART 00645 TO PART 00647 AROUND ENTIRE PERIMETER. MUST BE FLUSH.

RETAINING E-CLIP (00584), SILICA GEL PACK, AND ① EMC SUPPORT CARD (EMC-SUPRTCARD-001) TO BE INCLUDED IN POLY BAG WITH POWER LOCK ASSEMBLY.

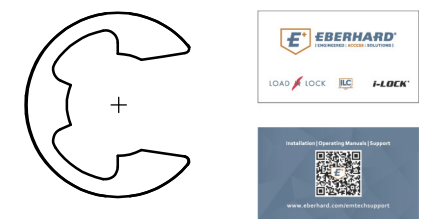

PARTS LIST

ITEM	QTY	PART NUMBER	DESCRIPTION
1	1	00645	SOLENOID FRAME, TOP MOUNT, EL2, ET10
2	1	00635	SOLENOID, LOCK .180" TRAVEL AT 2 LBS
3	1	00638	SLIDER PLATE, TOP MOUNT, EL2, ET10
4	2	00642	SOLENOID WIRE TERMINAL, 90 DEG. .250" MALE SPADE, SOLDER ON
5	2	00667	WASHER, SS, .188" ID, .440" OD
6	1	00647	SOLENOID COVER, TOP MOUNT
7	1	00584	EXTERNAL RETAINING RING
8	1	EMC-SUPRTCARD-001	EMC SUPPORT CARD

①

THIS DOCUMENT IS IN ACCORDANCE WITH ASME Y14.5-2009		
LINEAR MEASUREMENT: INCH	DATE	
UNLESS OTHERWISE SPECIFIED TOLERANCES ARE AS FOLLOWS:	11/09/2023	
	IN	MM
ANGLES:	± 2°	± 2°
2 PLACE DEC.:	± .03	± .76
3 PLACE DEC.:	± .015	± .38
ALL HOLES:	± .005	± .13

EBERHARD MANUFACTURING CO.
DIVISION OF
THE EASTERN COMPANY
CLEVELAND, OHIO 44149-9712

NAME: ES POWER MODULE, - 12VDC TOP MOUNT, EL2, ET10, ET13 MW/ CLIP

DATE: 11/09/2023

DWN. BY: sales

SCALE: 1:1

MATERIAL: _____

PART NUMBER: LNL-72-00651

D

C

B

A

D

C

B

A

C:\working_folder\Archive\LNL\LNL-72-XXXXXX\LNL-72-0066XX\LNL-72-00651.icg