

CONFIDENTIAL NOTICE: This drawing and the designs, specifications and engineering information disclosed hereon are the property of Eberhard Manufacturing Company and are not to be disseminated or reproduced without express written consent. The drawing is loaned in confidence and then only for consideration of the matter disclosed hereon. In accepting loan of this drawing, recipient agrees to keep it and the matter disclosed hereon in confidence and not to use nor permit their use in any way detrimental to Eberhard Manufacturing Company, Division of the Eastern Company, 21944 Drake Road, Cleveland, Ohio 44149-9712 © 2010 EBERHARD MFG. CO.

NO	CHANGE	ENG.NO.	DATE
	REVISED AND REDRAWN	EN 5005	7-20-01
1	REVISED NOTES & ADDED EBERHARD LOGO	EN 5031	1-25-02
2	ADDED PATENT INFORMATION	EN 5139	3-18-04
3	ADDED FMVSS 206 STICKER	EN 5394	1-9-08
4	ADDED Z3 FINISH	EN 5458	6-25-10

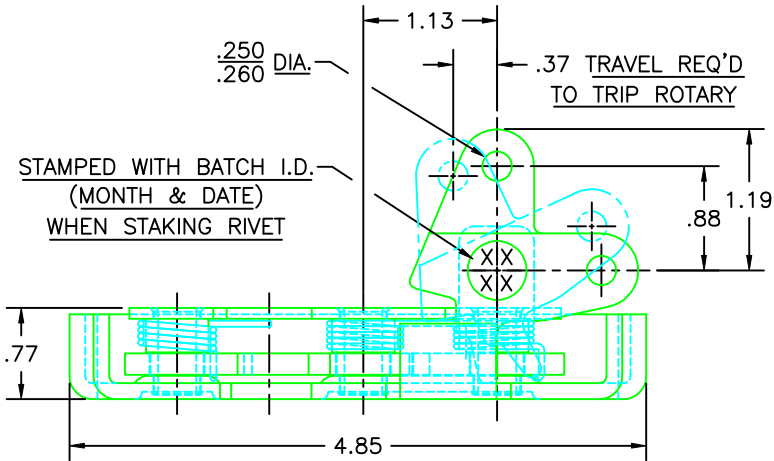

NOTES:

- USE 5/16 GRADE 8 BOLTS FOR INSTALLATION TO PASS FMVSS 206 SAFETY STANDARD.
- RECOMMENDED TORQUE FOR TIGHTENING: 130 ±10 in./lbs.



1 AVAILABLE FINISHES:

- (23) E-COAT
- (25) ELECTROPLATED ZINC
- (BG) BEARING GREASE WITH EVERLUBE INTERNAL COMPONENTS.

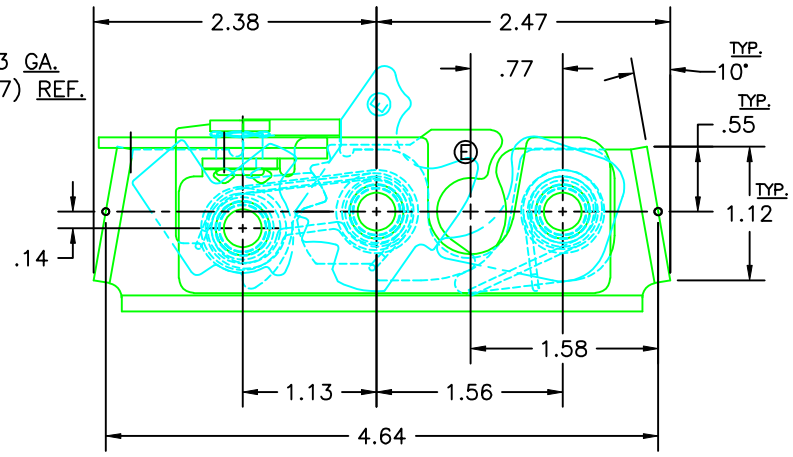
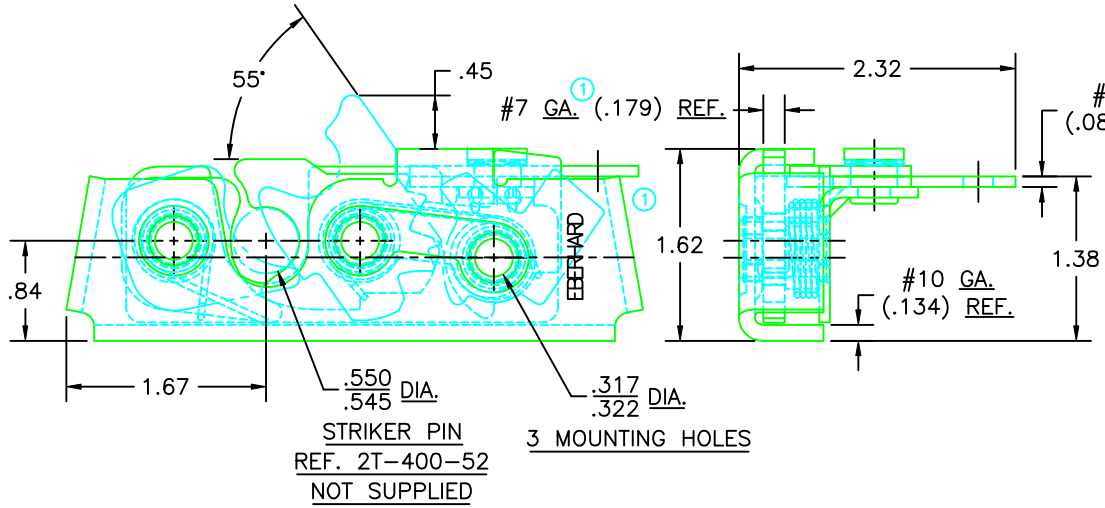
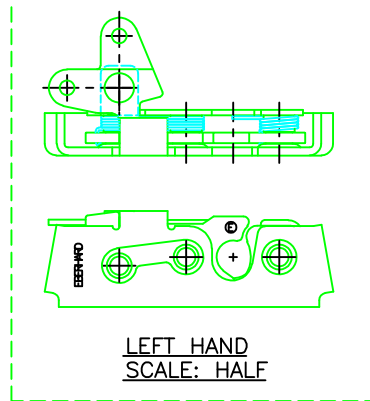

CUSTOMER PRINT
SHEET 1 OF 2
RIGHT HAND SHOWN
LEFT HAND OPPOSITE

FOR ADDITIONAL INFORMATION SEE:
9D-400-UR/L - DOVETAIL ROTARY LOCK AND STRIKER MOUNTING BRACKET ASSEMBLY.
D-400-53 - DOVETAIL AND STRIKER LOCATOR ASSEMBLY.

PAT. No. 4,896,906
DES. PAT. No. 304,291

SUPERSEDES DRAWING 9D-400-R/L SHEET 1 OF 2 DATED 10-7-93.

EBERHARD MANUFACTURING CO.
DIVISION OF
THE EASTERN COMPANY
CLEVELAND, OHIO 44149-9712

UNLESS OTHERWISE SPECIFIED TOLERANCES ARE AS FOLLOWS:	DATE 7-17-01
ANGLES: ±2°	DR./BY A.L.
2 PLACE DEC.: ±.03	SCALE FULL
3 PLACE DEC.: ±.015	CHK./BY
ALL HOLES: ±.005	

NAME DOVETAIL / ROTARY (LESS STRIKER)	PART NUMBER 9D-400-R/L
MATERIAL -----	