

CONFIDENTIAL NOTICE: This drawing and the designs, specifications and engineering information disclosed herein are the property of Eberhard Manufacturing Company and are not to be disseminated or reproduced without express written consent. The drawing is loaned in confidence and then only for consideration of the matter disclosed herein. In accepting loan of this drawing, recipient agrees to keep it and the matter disclosed herein in confidence and not to use nor permit their use in any way whatsoever by Eberhard Manufacturing Company, Division of the Eastern Company, 21844 Drake Road, Cleveland, Ohio 44148-9712. © 2015 EBERHARD MFG. CO.

REVISION HISTORY					
REV	DESCRIPTION	EN	DATE	REV BY	APVD BY
1	CONVERTED TO 3D	5724	10-9-15	FLP	MR

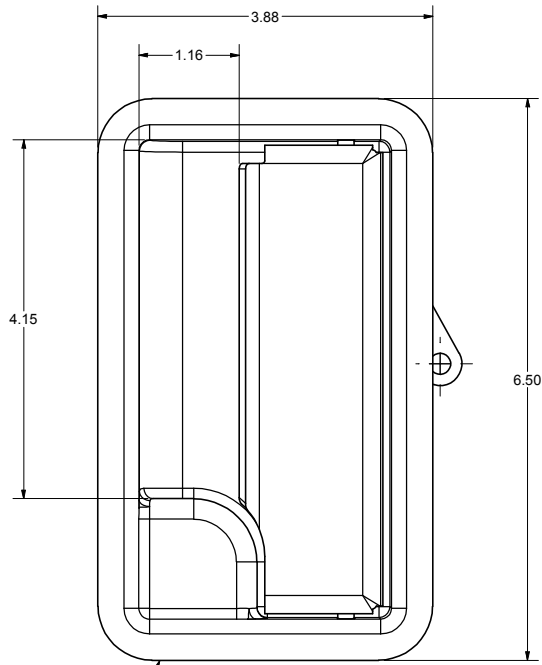

PADDLE HANDLE & RECEPTACLE SUB-ASSEMBLY

REF.  
GRAIN DIRECTION  
FOR BRUSHED  
STAINLESS STEEL  
FINISH ONLY.

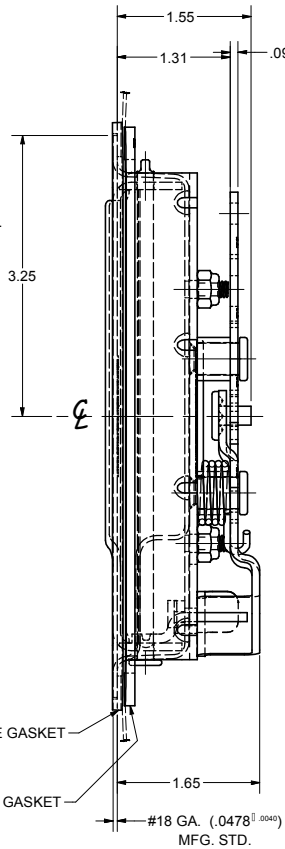

OUTSIDE GASKET  
FOR VERTICAL  
DOORS ONLY  
INSIDE GASKET

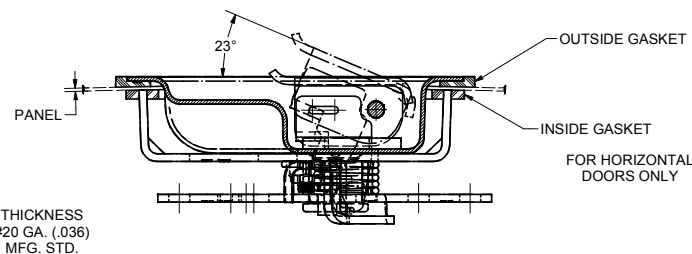

THICKNESS  
#20 GA. (.036)  
MFG. STD.

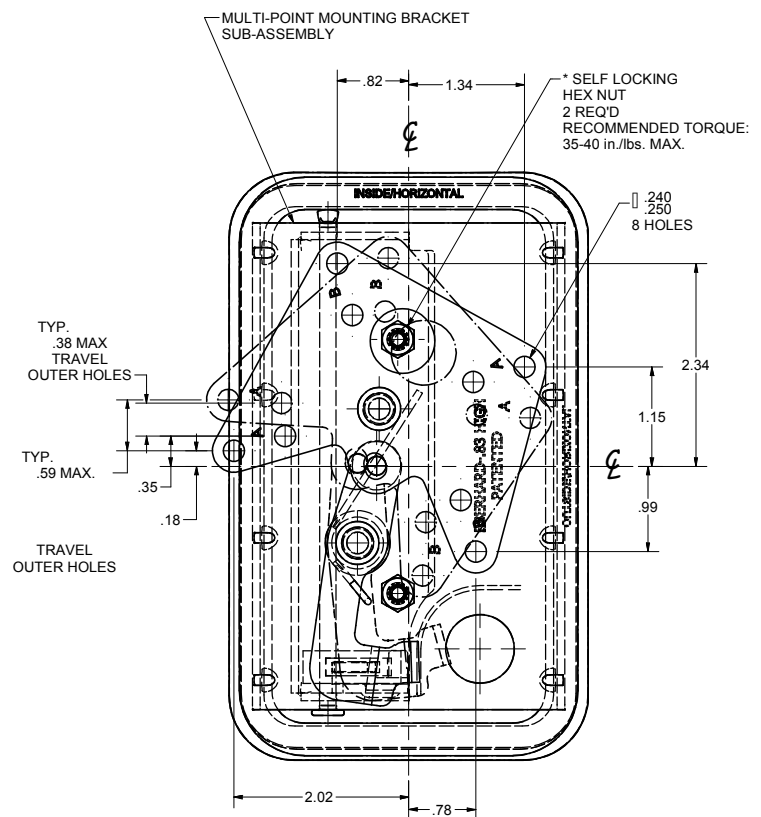

MULTI-POINT MOUNTING BRACKET SUB-ASSEMBLY

\* SELF LOCKING  
HEX NUT  
2 REQ'D  
RECOMMENDED TORQUE:  
35-40 in./lbs. MAX.

TYP.  
.38 MAX  
TRAVEL  
OUTER HOLES  
TYP.  
.59 MAX.  
TRAVEL  
OUTER HOLES

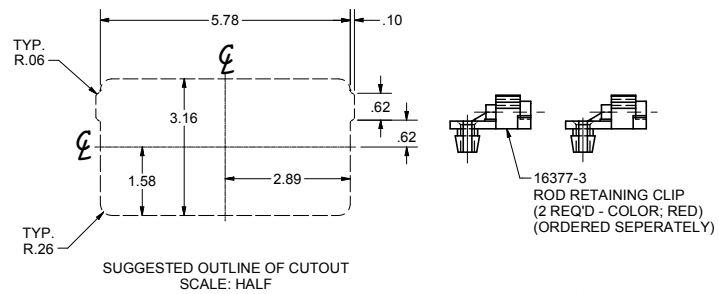

SUGGESTED OUTLINE OF CUTOUT  
SCALE: HALF

NOTE:  
PART NUMBER 9773-PK INCLUDES PADDLE HANDLE AND RECEPTACLE SUB-ASSEMBLY, MULTI-POINT MOUNTING BRACKET SUB-ASSEMBLY, RECEPTICAL & GASKETS (INSIDE AND OUTSIDE), AND P5 FASTENER PACKAGE SHIPPED IN A P-12D DOUBLE POLY BAG.

\* P5 FASTENER PACKAGE INCLUDES SELF LOCKING HEX NUTS (2 REQ'D)

RECEPTACLE GASKETS AND 16377-3 ROD RETAINING CLIPS (2 REQ'D-COLOR: RED) TO BE ORDERED SEPARATELY.

CUSTOMER PRINT SHEET 1 OF 2

<b>EBERHARD MANUFACTURING CO.</b>	
DIVISION OF THE EASTERN COMPANY CLEVELAND, OHIO 44148-9712	
MULTI-POINT NON LOCKING ASSEMBLY	
MATERIAL	PART NUMBER
-----	9773-PK

③ PART NUMBER	FINISH CODE	FINISH DESCRIPTION
9773-PK	(33)	BLACK POWDER COAT W/BRUSHED STAINLESS HANDLE

SUPERSEDES DRAWING 9773-PK CHART SHEET 1 OF 2 DATED 10-18-99.