

CONFIDENTIAL NOTICE: This drawing and the designs, specifications and engineering information disclosed hereon are the property of Eberhard Manufacturing Company and are not to be disseminated or reproduced without express written consent. The drawing is loaned in confidence and then only for consideration of the matter disclosed hereon. In accepting loan of this drawing, recipient agrees to keep it and the matter disclosed hereon in confidence and not to use nor permit their use in any way whatsoever by Eberhard Manufacturing Company, Division of the Eastern Company, 27944 Drake Road, Cleveland, Ohio 44149-9712. © 2013 EBERHARD MFG. CO.

REVISION HISTORY			
REV	DESCRIPTION	EN	DATE
1	CONVERTED TO 3D	5614	7-26-13

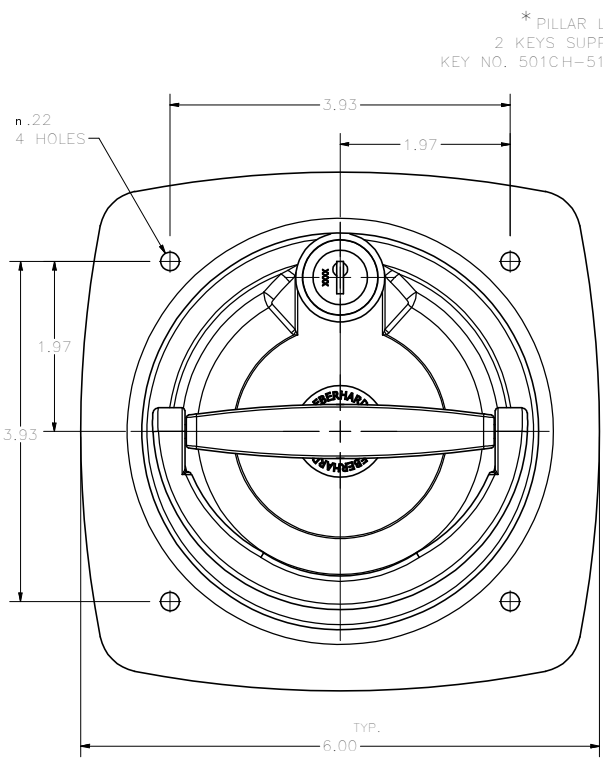

* PILLAR LOCK
2 KEYS SUPPLIED
KEY NO. 501CH-510CH

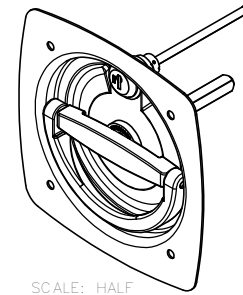
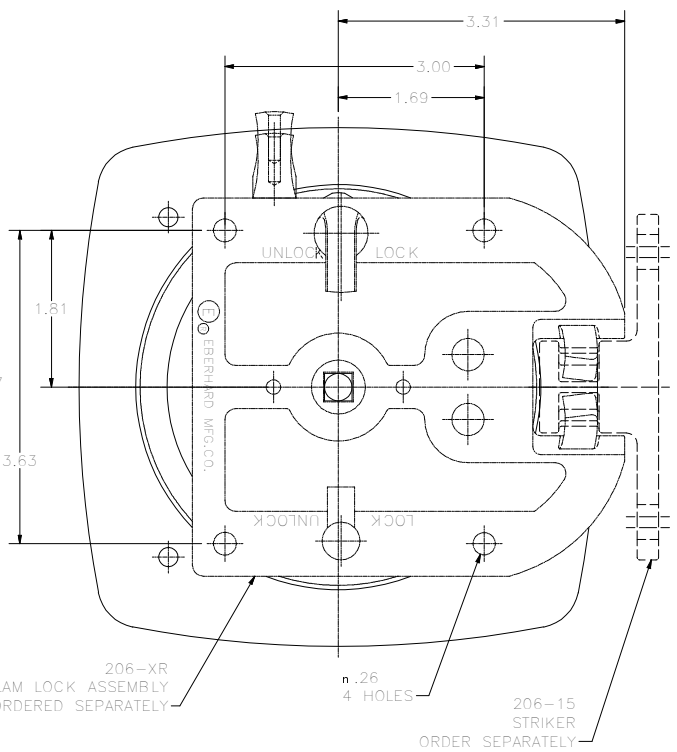
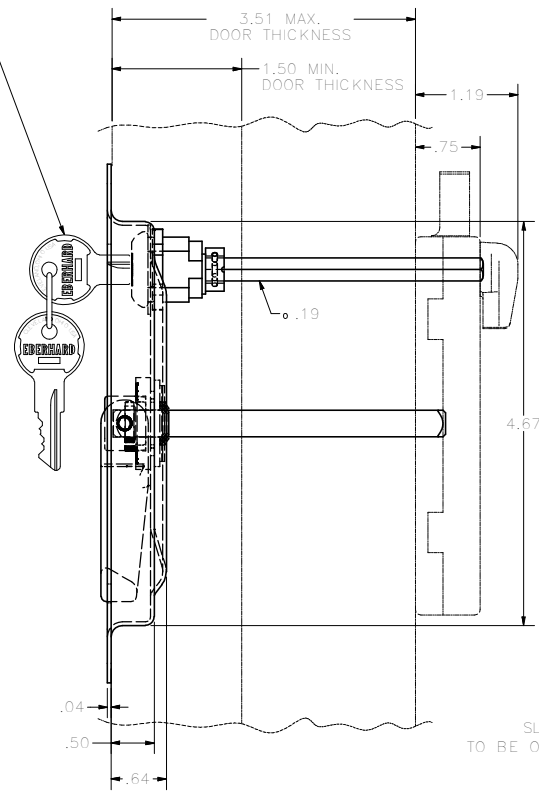

- NOTES:
- CUSTOMER TO CUT SHANKS TO REQUIRED LENGTHS.
 - TO COMPLY WITH FMVSS 206 STANDARDS, THE 206-XR/L SLAM LOCK MUST BE INSTALLED IN CONJUNCTION WITH EBERHARD'S 206-15 STRIKER IN A CERTIFIED FMVSS 206 DOOR SYSTEM.

PART NO.	FINISH	DESCRIPTION
9000-SSPL (32)	(32) STAINLESS, RECEPT. W/ BLACK HANDLE	PILLAR LOCKING W/4 MTG. HOLES

THIS DOCUMENT IS UNCLASSIFIED WITH EXCEPT WHERE SHOWN OTHERWISE	DATE 014-13-2005
UNLESS OTHERWISE SPECIFIED TOLERANCES ARE AS FOLLOWS:	7/26/2013
ANGLES: 12° 12°	FLP
2 PLACE DEC: ±.05 ±.06	FULL
3 PLACE DEC: ±.015 ±.08	
4 PLACE DEC: ±.004 ±.12	

CUSTOMER PRINT
SHEET 1 OF 3
RIGHT HAND SHOWN
LEFT HAND OPPOSITE

EBERHARD MANUFACTURING CO.
DIVISION OF
THE EASTERN COMPANY
CLEVELAND, OHIO 44149-9712

RECESSED "D" HANDLE
ASSEMBLY (PILLAR LOCKING)

9000-SSPL

SUPERSEDES DRAWING 9000-SSPL CHART SHEET 1 OF 3 DATED 10-21-05.