

CONFIDENTIAL NOTICE: This drawing and the designs, specifications and engineering information disclosed hereon are the property of Eberhard Manufacturing Company and are not to be disseminated or reproduced without express written consent. The drawing is loaned in confidence and then only for consideration of the matter disclosed hereon. In accepting loan of this drawing, recipient agrees to keep it and the matter disclosed hereon in confidence and not to use nor permit their use in any way detrimental to Eberhard Manufacturing Company, Division of the Eastern Company, 21944 Drake Road, Cleveland, Ohio 44149-9712 © 2016 EBERHARD MFG. CO.

REVISION HISTORY					
REV	DESCRIPTION	EN	DATE	REV. BY	APVD. BY
	REVISED AND REDRAWN	5805	6/2/2017	RHC	LSW
1	ADDED (64) FINISH	5806	06/09/2017	MAM	LSW
2	REMOVE (25) ADD (54)	5851	5/4/2018	VRB	MR

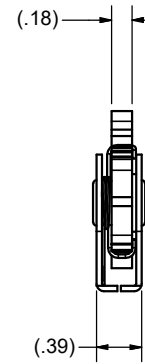
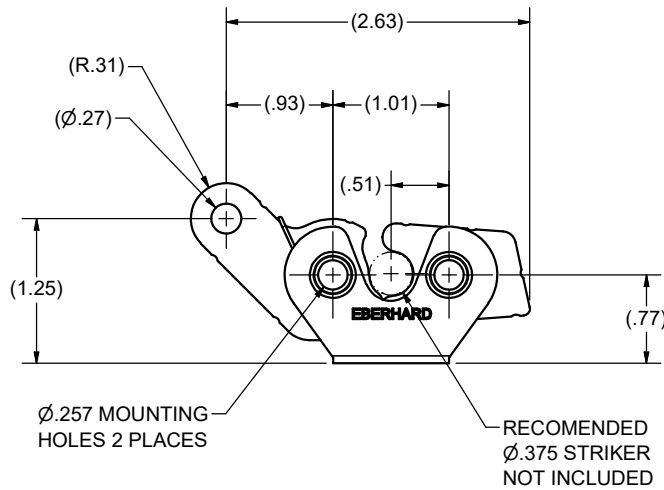
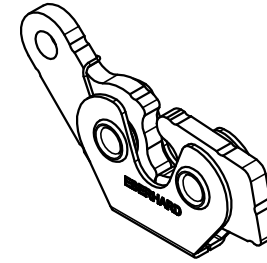
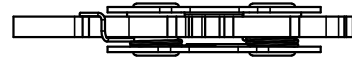

NOTES:

- 1) COMPONENTS TO MOVE FREELY WITHOUT BINDING AFTER ASSEMBLY WHEN MOUNTED.
- 2) MAX. TIGHTENING TORQUE: 8 FT/LBS.
- 3) FINISHES:  
 (54) EVERLUBE INTERNALS WITH (64) ZINC W/YELLOW CONVERTER COVERS. ②  
 (64) ZINC W/ YELLOW CONVERTER ①

SUPERSEDES DRAWING 200 SH1 DATED 06-09-10.

CUSTOMER PRINT  
SHEET 1 OF 2

**EBERHARD MANUFACTURING CO.**  
DIVISION OF  
**THE EASTERN COMPANY**  
CLEVELAND, OHIO 44149-9712

THIS DOCUMENT IS IN ACCORDANCE WITH ASME Y14.5-2009	
LINEAR MEASURE: INCH	DATE: 6/2/17
UNLESS OTHERWISE SPECIFIED	DR. BY: RHC
TOLERANCES ARE AS FOLLOWS:	SCALE: FULL
IN MM	CHK. BY:
ANGLES: ± 2' ± 2'	
2 PLACE DEC.: ± .03 ± .76	
3 PLACE DEC.: ± .015 ± .38	
ALL HOLES: ± .005 ± .13	

NAME: COMPACT ROTARY LOCK	
MATERIAL: -----	PART NUMBER: 200