

**CONFIDENTIAL NOTICE:** This drawing and the designs, specifications and engineering information disclosed herein are the property of Eberhard Manufacturing Company and are not to be disseminated or reproduced without express written consent. The drawing is loaned in confidence and then only for consideration of the matter disclosed herein. In accepting loan of this drawing, recipient agrees to keep it and the matter disclosed herein in confidence and not to use nor permit their use in any way detrimental to Eberhard Manufacturing Company, Division of the Eastern Company, 21944 Drake Road, Cleveland, Ohio 44149-9712 © 2016 EBERHARD MFG. CO.

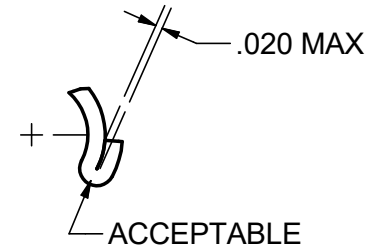
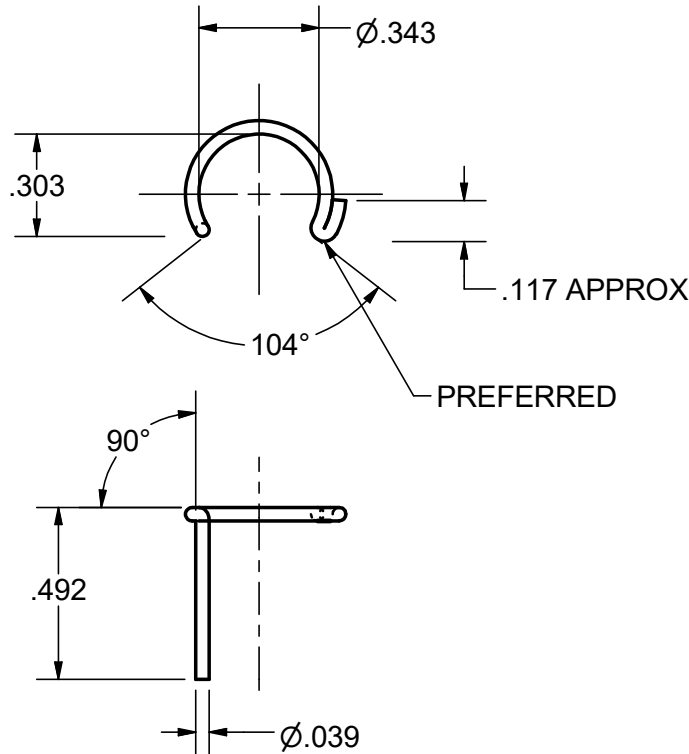
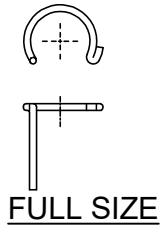

- NOTES:  
 1. FINISH: ZINC PLATED WITH YELLOW CONVERTOR FC (65)  
 2. USE WITH BALL STUD PART NUMBER 16298-24

CUSTOMER PRINT  
SHEET 1 OF 2

						LINEAR MEASURE: INCH UNLESS OTHERWISE SPECIFIED TOLERANCES ARE AS FOLLOWS: IN MM ANGLES: $\pm 2'$ $\pm 2'$ 2 PLACE DEC.: $\pm .03$ $\pm .76$ 3 PLACE DEC.: $\pm .015$ $\pm .38$ ALL HOLES: $\pm .005$ $\pm .13$		DATE 3/11/2016 DR. BY GJB SCALE 2X CHK. BY MR		<b>EBERHARD MANUFACTURING CO.</b> DIVISION OF <b>THE EASTERN COMPANY</b> CLEVELAND, OHIO 44149-9712		NAME SAFETY RETAINING CLIP 25 MM SIZE, <sup>①</sup> FOR 10 MM BALL STUD	
1	REVISE TITLE	5821	9-22-17	FLP	MR			THIS DOCUMENT IS IN ACCORDANCE WITH ASME Y14.15-2009		MATERIAL SEE ABOVE		PART NUMBER 16299	
1	RELEASED	5743	03/11/2016	GJB	MR								
REV	DESCRIPTION	EN	DATE	REV BY	APVD BY								

C:\TEMP\id6c30b59-f62f-4f0c-9f17-5fc49dfe83ce\FASTENER\CLIPSWIRE FORM\16299 SH1.idw